



SAN BRUNO RECREATION & AQUATIC CENTER

San Bruno Community
Foundation Update

September 6, 2023





AGENDA

1. Construction Update and Look Ahead Schedule
 - a) Project Information Update
 - b) Completed To Date
 - a) Broadcasting Capabilities Update
 - b) Contaminated Soil Update
 - c) Schedule Update (Public Outreach)
 - d) What's Happening the Next 30 Days and Beyond?
 - e) Adopted Projects Update
 - I. City Park Way and Crystal Springs Intersection
 - II. Beckner Shelter Road Projects
 - f) Change Order and Project Budget Update
 - g) Project Overview and Outlook
2. Questions

Construction Update and Look Ahead Schedule



PROJECT INFORMATION



Start Date: September 2021



Project Completion: End of 2023



Estimated Cost Completed To Date: 75.83% (July 2023)



EarthCam Link: https://share.earthcam.net/RecCenterBuild/rec_center_build/camera/view_1



Multivista Aerial Photo on 06/06/23



Multivista Aerial Photo on 08/30/23

Construction Update and Look Ahead Schedule

COMPLETED TO DATE (Through 09/05/23)



June 6, 2023



September 5, 2023



Construction Update and Look Ahead Schedule

COMPLETED TO DATE



BUILDING UPDATE



NATATORIUM

- **Exterior**
 - Framing of Exterior Walls ongoing
- **Indoor Pool**
 - Pool Deck Plumbing ongoing
 - Cantilevered Gutter ongoing

GYMNASIUM/COMMUNITY HALL

- **Roof**
 - Flat Roof TPO completed
 - Insulation for High Roofs (Natatorium, Gymnasium, and Community Hall) ongoing
 - MEP Roof Duct Work Ongoing

Exterior Walls

- Continue EIFS Installation
- Window mockup ongoing
- Window Installation at the East side ongoing
- Stone Veneer Attachment Clips at North Side Installed

Interior

- Interior Insulation and Drywall Installation in progress
- Painting of Main Electrical Rooms ongoing
- Electrical Rough for Broadcasting ongoing
- Framing of wall dividing Gymnasium from Natatorium
- Community Lounge and Natatorium Stairs

Construction Update and Look Ahead Schedule

COMPLETED TO DATE

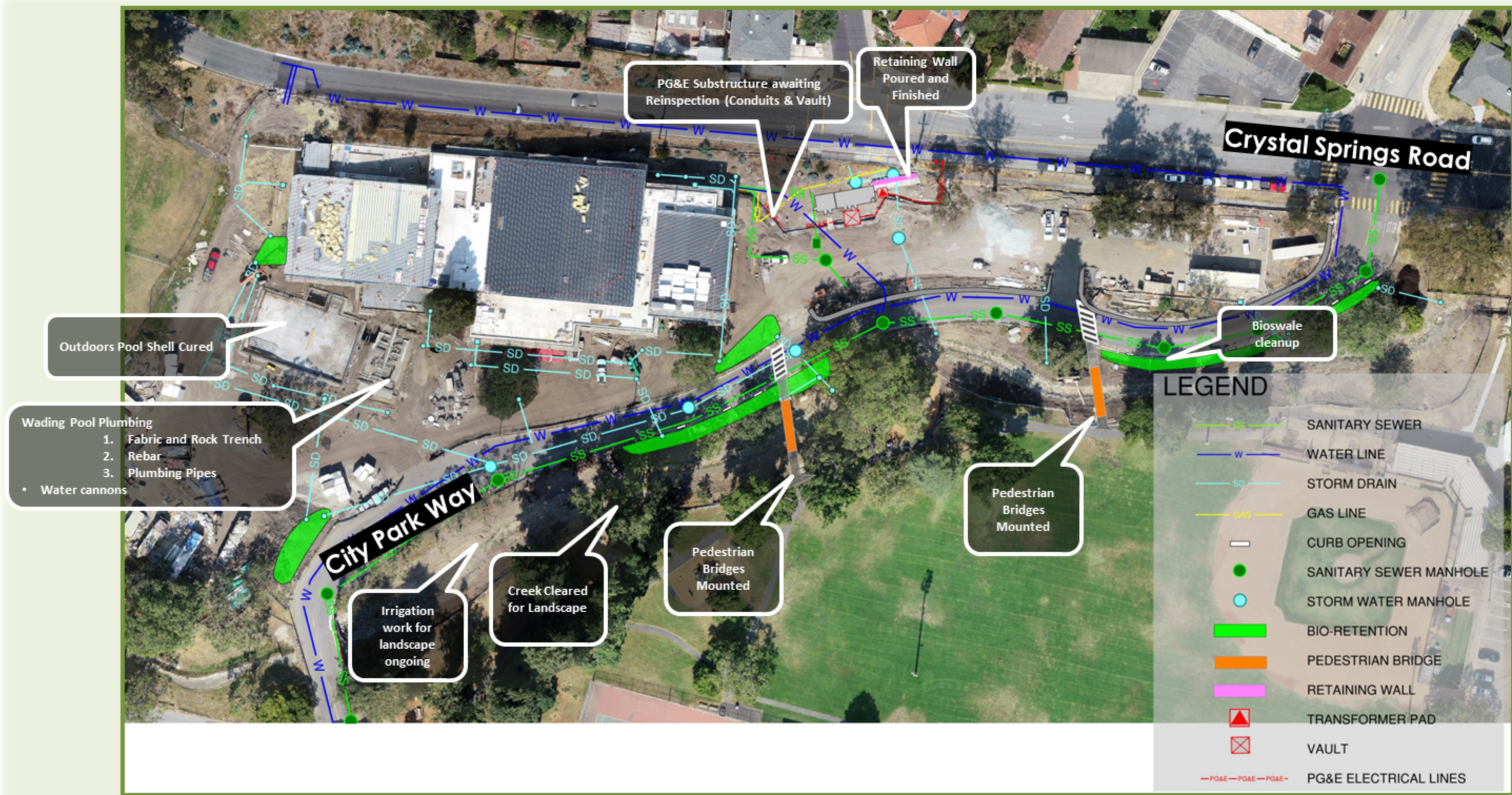

Construction Update and Look Ahead Schedule



COMPLETED TO DATE

ONSITE UPDATE: FLAT ROOF and HIGH ROOF

Completed

- Flat Roof Insulation is completed
- High Roof Insulation is ongoing



1 – Completed TPO Flat Roof

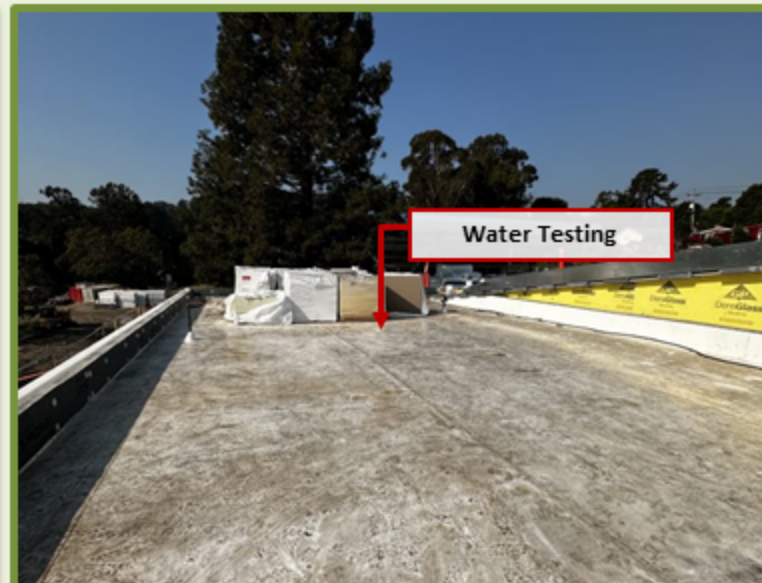

2 - Completed TPO Flat Roof



3 – Completed TPO Flat Roof

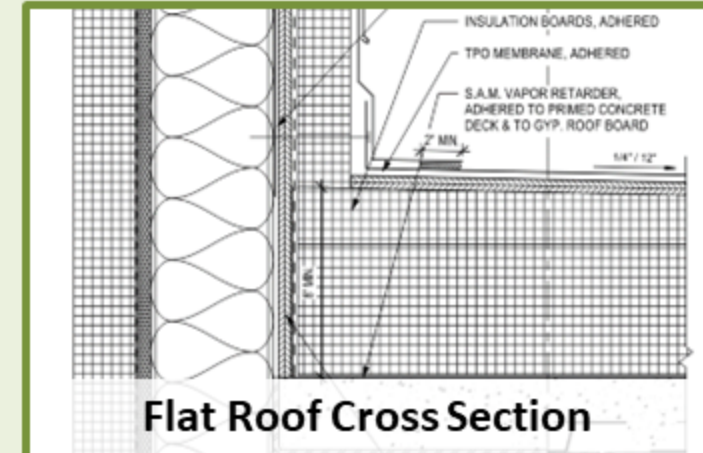

Flat Roof Cross Section



4 - Community Hall Roof Preparation



5 - Gymnasium High Roof

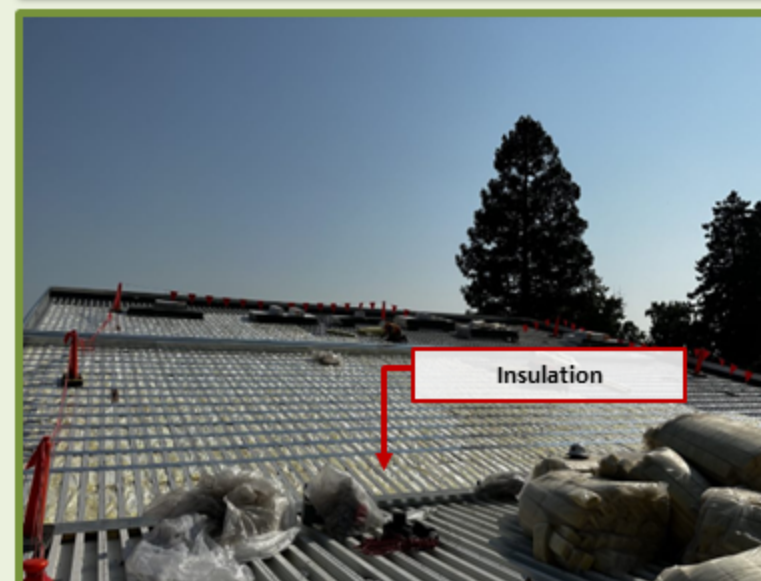

6 - Natatorium High Roof Insulation



High Roof Cross Section



Flat Roof

Construction Update and Look Ahead Schedule

COMPLETED TO DATE



ONSITE UPDATE: EXTERIOR WALLS



EIFS Finishing



Stone Veneer Wall



Window Mockups

Completed

- Waterproofing Spray
- Window and Door Flashing Installation ongoing
- EIFS Foam Mockup (Final layer of the exterior walls)
- Stone Veneer Attachment Clips ongoing

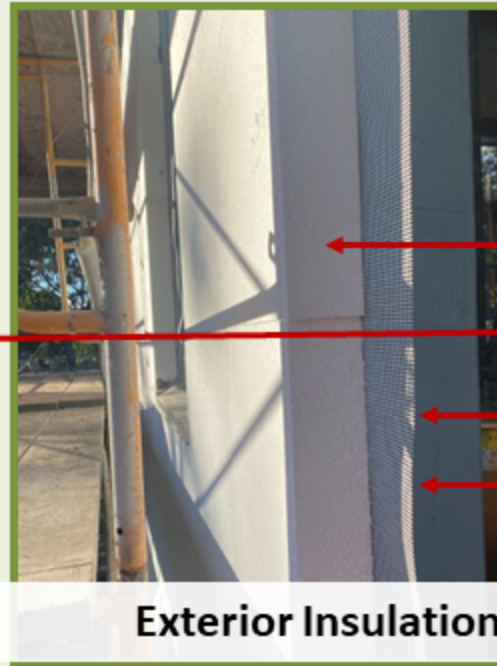
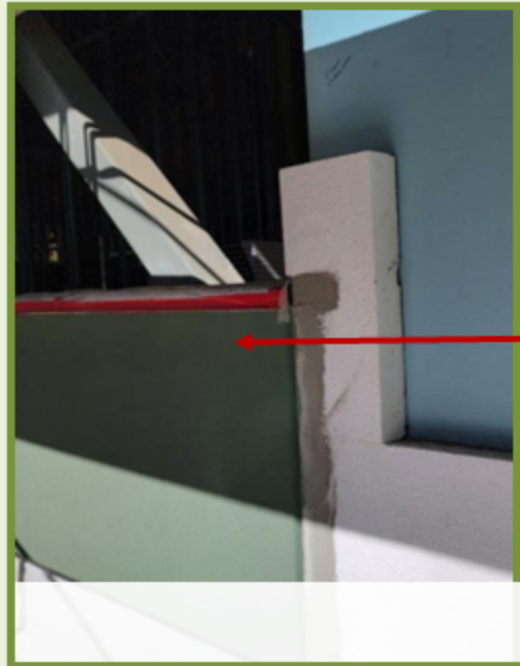

- ← Foam Board Insulation →
- ← EIFS Finish →
- ← Waterproofing →
- ← Sheathing →

Exterior Insulation Finishing System (EIFS) Mockup

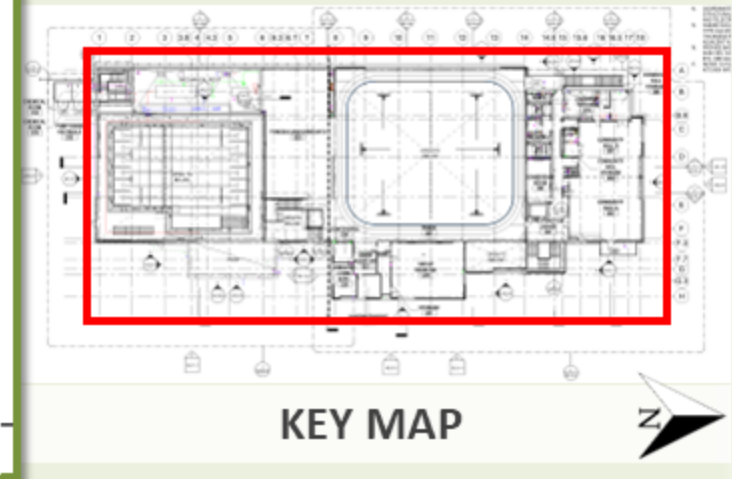
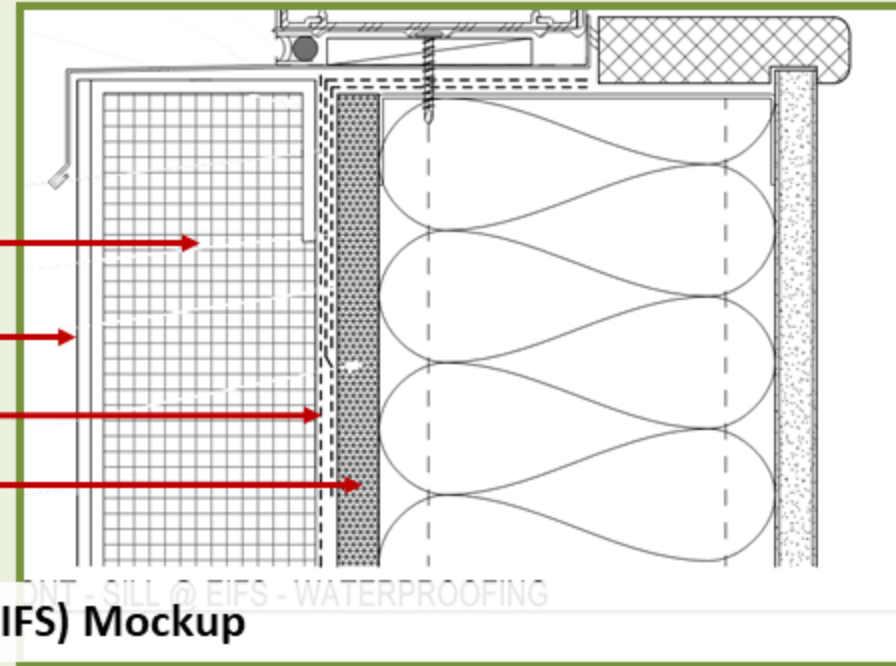

KEY MAP

Construction Update and Look Ahead Schedule

COMPLETED TO DATE



ONSITE UPDATE: INTERIOR



1 – Insulation and Window Work



2 - Drywall Progress



3 – Electrical Room Painting



4 – Preparation for Windows



5 – Community Lounge Stairs



6 – Pool Lobby Stairs

Completed

- Interior insulation
- Window mockup
- Drywall
- Painting of main electrical room
- Door Framing ongoing
- Community Lounge and Natatorium Stairs ongoing

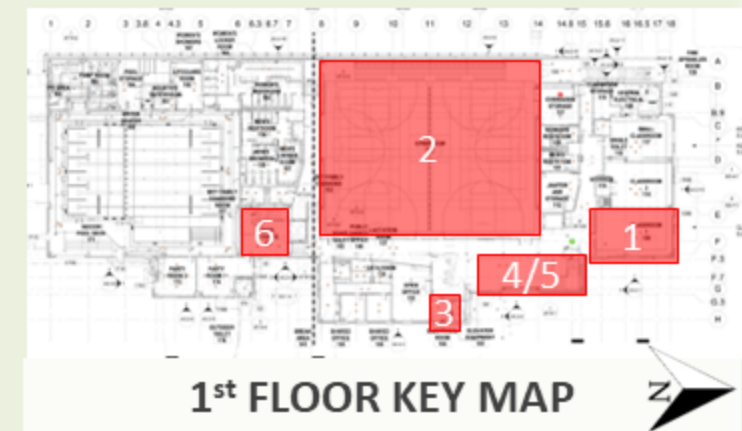

Construction Update and Look Ahead Schedule

COMPLETED TO DATE



ONSITE UPDATE: NATATORIUM



Pool Deck Plumbing



Tiling at Water Line



Scaffolding

Scaffolding for Natatorium Ceiling/MEP



Completed Pool Shell - South

Completed

- Indoor Pool
 - Pool Deck Plumbing ongoing
 - Cantilevered Gutter in progress
 - Tiling at the water line completed
- Scaffolding



RENDERING - NORTHEAST

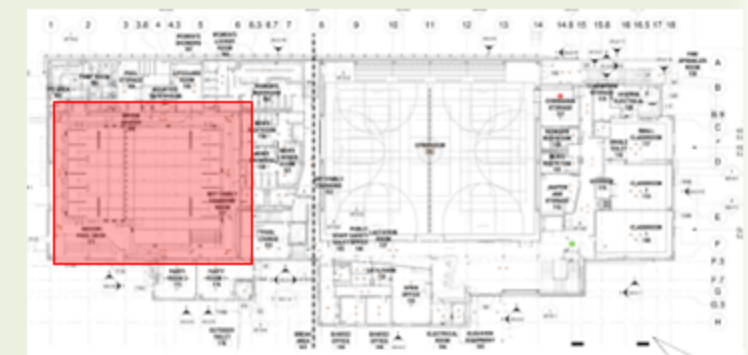

KEY MAP

Construction Update and Look Ahead Schedule

COMPLETED TO DATE



OFFSITE UPDATE: OUTDOOR POOLS



Outdoor Pools



1 - Outdoor Pool Shell and Gutter Rebar



2 - Wading Pool Excavation and Plumbing Trench Excavation/Rebar



3 - Wading Pool Plumbing Concrete Pour

Completed

- Outdoor Pool Shell Curing completed
- Outdoor Pool Gutter Rebar
- Wading Pool
 - Plumbing Trenches poured
 - Plumbing for Water features



RENDERING - NORTHEAST

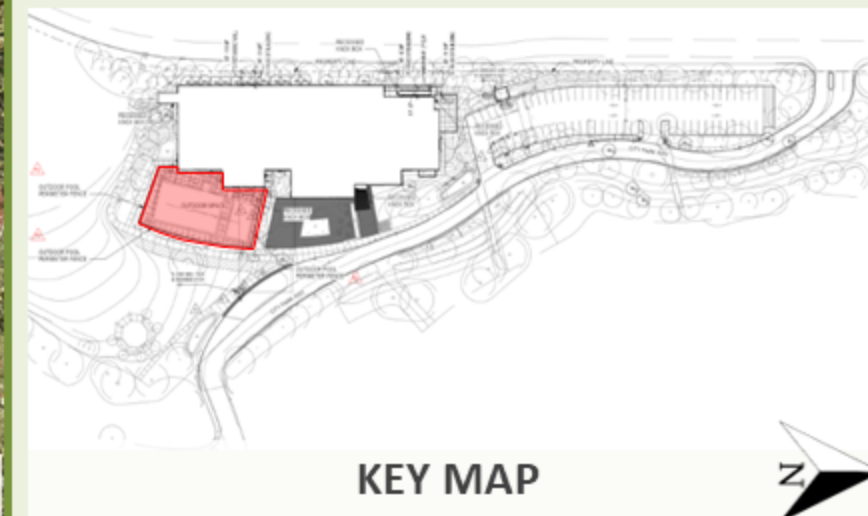

KEY MAP

Construction Update and Look Ahead Schedule

COMPLETED TO DATE



OFFSITE UPDATE: PG&E

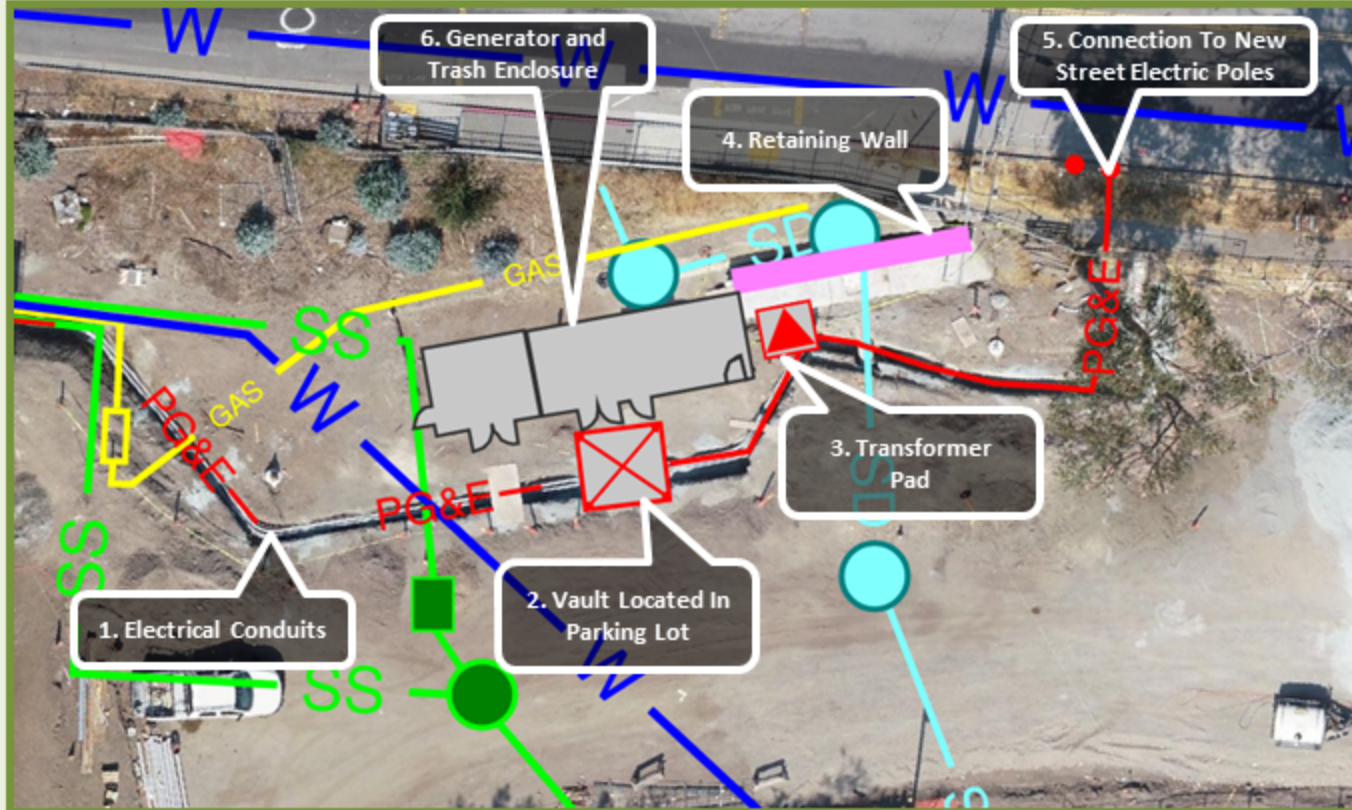

PG&E Work Schedule

1. Received PG&E Plans – 5/16/23
2. Completed - Preconstruction Meeting (6/8/23)
3. Completed - Contractor installing PG&E substructures
4. (8/18 and 8/21) – PG&E Trench Inspection
5. **(9/7) PG&E Reinspection**
6. **(TBD)** - Transformer pad
7. **(TBD)** - PG&E Inspection (mandrel testing) and transformer/ pad inspection
8. **(TBD)** - PG&E install New pole, Transformer and cables
9. **(TBD)** - City Building Inspection and tagging for meter
10. **(TBD)** - PG&E to confirm meter release and for power drop



Construction Update and Look Ahead Schedule

COMPLETED TO DATE



OFFSITE UPDATE: CREEK WORK



Mounted Pedestrian Bridge



- CREEK and PARK**
- Pedestrian Bridge Abutments
 - Irrigation work ongoing
 - Bioswale Clean Up

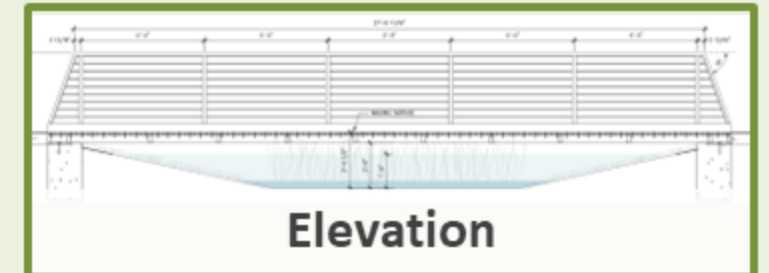

Elevation



Bioswale Cleanup



Irrigation Work

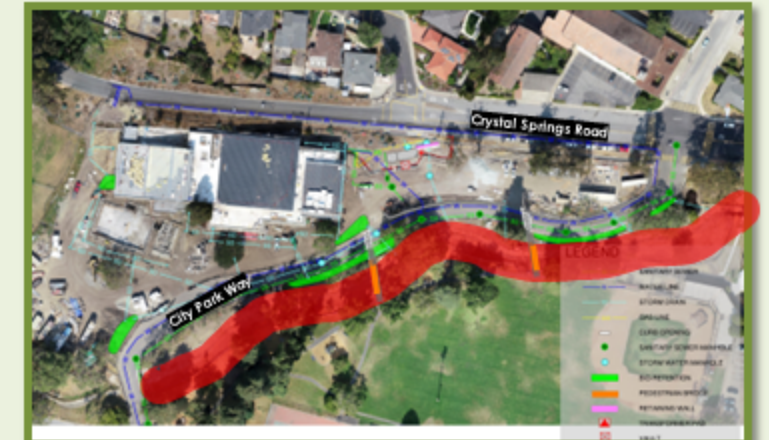

KEY MAP

Construction Update and Look Ahead Schedule

COMPLETED TO DATE



BROADCASTING CAPABILITIES

1. GYMNASIUM

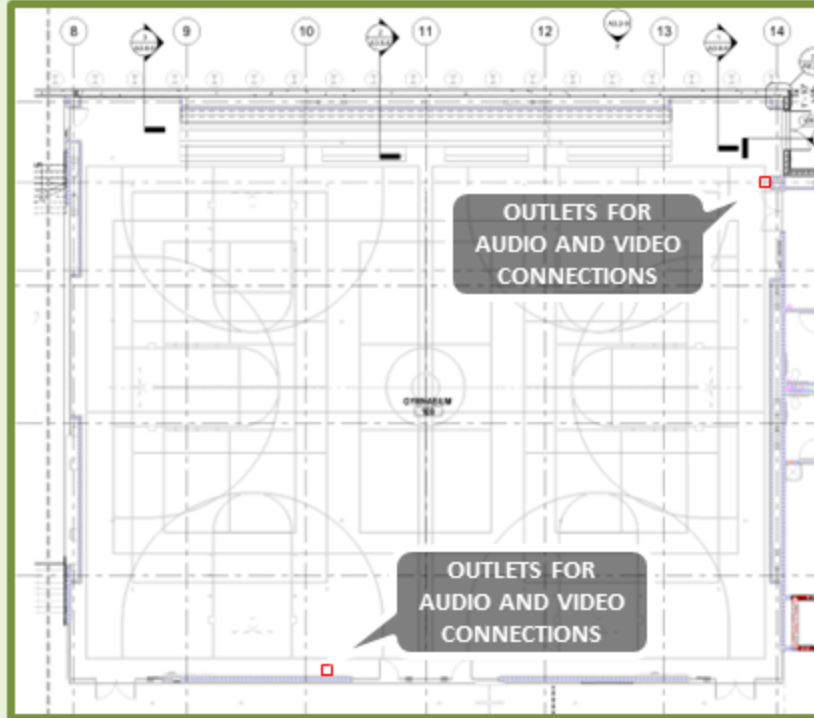

2. PLAZA



3. COMMUNITY HALL

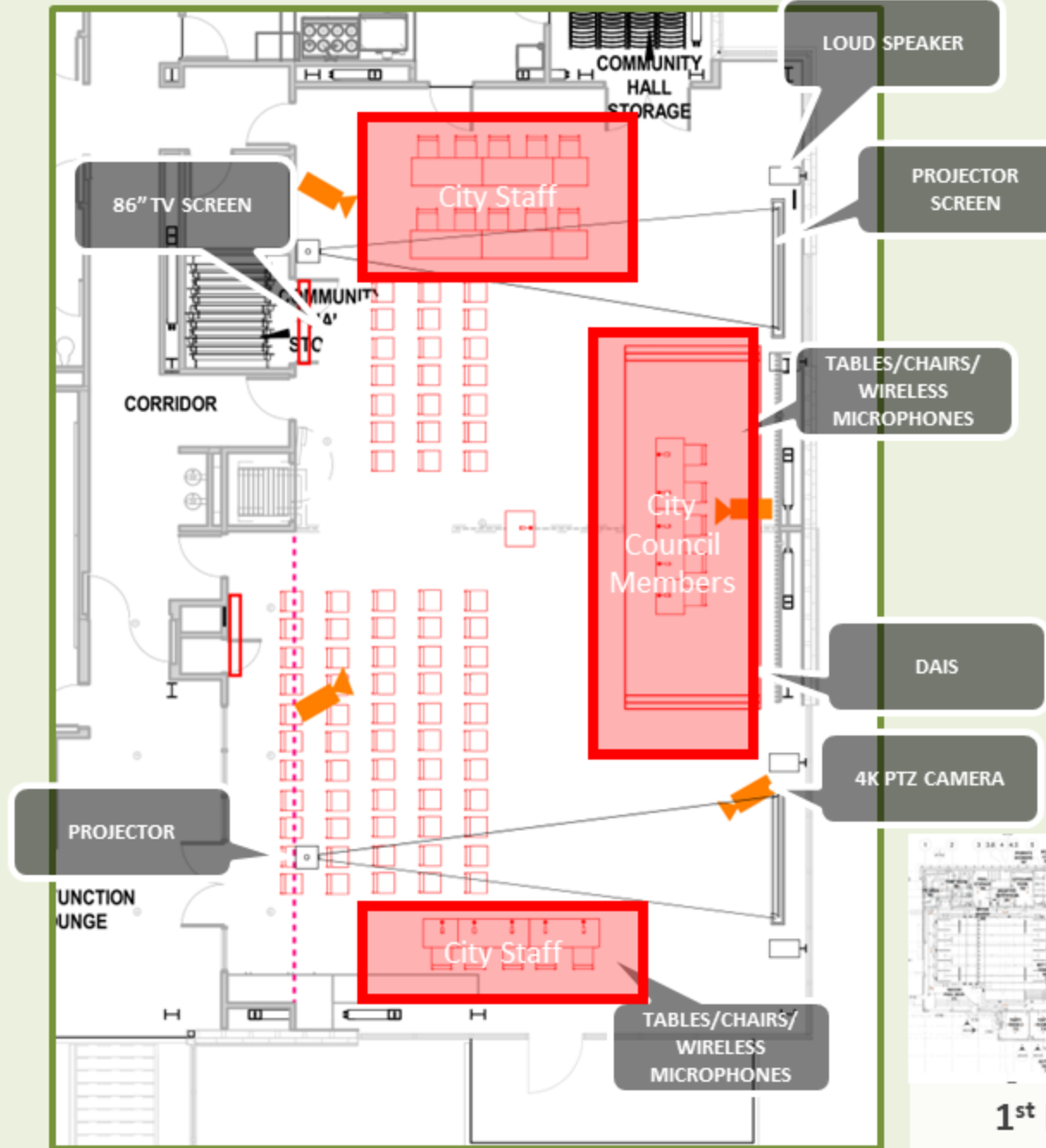

Locations with Broadcasting Capability:

1. Gymnasium (SDI Connections) – Live Stream events
2. Plaza (SDI Connections) – Live Stream events
3. Community Hall (SDI Connections and Permanent Broadcasting System Setup)

Community Hall Features for Council Meetings:

1. Four (4) 4K PTZ Cameras
2. Wireless microphones
3. Two (2) 86" TV Screens
4. Integrated to existing AV system to utilize:
 - Two (2) Projectors and Screens
 - Four (4) Wall Mounted Speakers
 - Twelve (12) Ceiling Mounted Speakers



Construction Update and Look Ahead Schedule

COMPLETED TO DATE



CONTAMINATED SOIL UPDATE

Test Date: 3/8/22

Purpose: Excavation from soil nail wall
Result: Petroleum and other compounds (Class II/III Non-Hazardous Waste)

Test Date: 7/18/22

Purpose: Water Line Trenching
Result: Petroleum and other compounds (Class II/III Non-Hazardous Waste)

Test Date: 6/21/22

Purpose: Creek Modification and Excavation
Result: Dieldrin pesticides, petroleum hydrocarbons (Class II/III Non-Hazardous Waste)

Test Date: 5/18/22

Purpose: Building Footing and Pool Excavation
Result: Petroleum and other compounds (Class II/III Non-Hazardous Waste)



Contractor's Responsibility: To test existing soil (*Project Specifications Section 32-9113 Soil Preparation*)

Required: Disposal of soil in a Class II landfill (*California Water Code Section 13050*)

Possible Sources of Contaminants:

- Petroleum in soil is common due to rain washing down leaks and spills from cars into the soil.
- Pesticides may come from past uses of the land.

Environmental Impact: Potential for contamination of environment (waterways, water resources, etc.)

Mitigation Measures:

- Excavated Soil – Disposal of soil in a Class II landfill for containment.
- Dust - Per Caltrans, dust is to be controlled through use of water or dust suppressants.
- Disturbed Areas - Excavated to subgrade and topped with layers of base rock and pavement, or encapsulated with topsoil for future planting.

Disturbed Areas (To be topped up per details below)

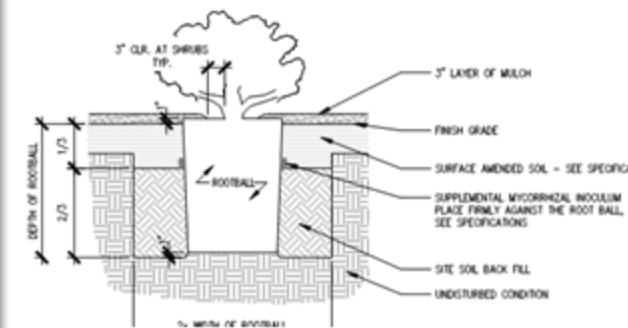

Shrub Planting Section- Detail

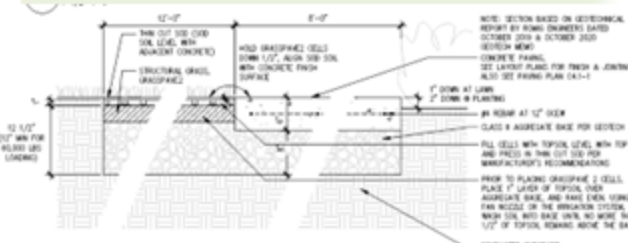

Concrete Paving Section- Detail

Construction Update and Look Ahead Schedule

COMPLETED TO DATE



SOIL TESTING DEFINITIONS

Soil Class	Pollutant Types	Pollutant Levels	Human Health	Water Quality Impact	Plant Restrictions
Class I (Hazardous Waste)	Hazardous Materials (Ex. Lead and high levels of hydrocarbons)	Significant	Most threatening (When improperly managed)	Significant	Least Limited
Class II (Designated Waste)	Fuel Oils, Residual Fuel Oils, Lubrication Oils, [...] Other Petroleum Products Not Listed In Class I.	Moderate	Less threatening	Moderate (Exceeds Regulatory Requirements)	Moderately Limited
Class III (Designated Non-hazardous Waste)	Inert waste (Garbage, Trash, Industrial Waste, rock, brick, glass, etc.)	Lowest	Potential To Indirectly Impact	Lowest	Most Limited

Sources:

- [USDA Agricultural Research Service](#)
- [Regional Water Quality Control Board](#)
- [Environmental Protection Agency](#)

Construction Update and Look Ahead Schedule

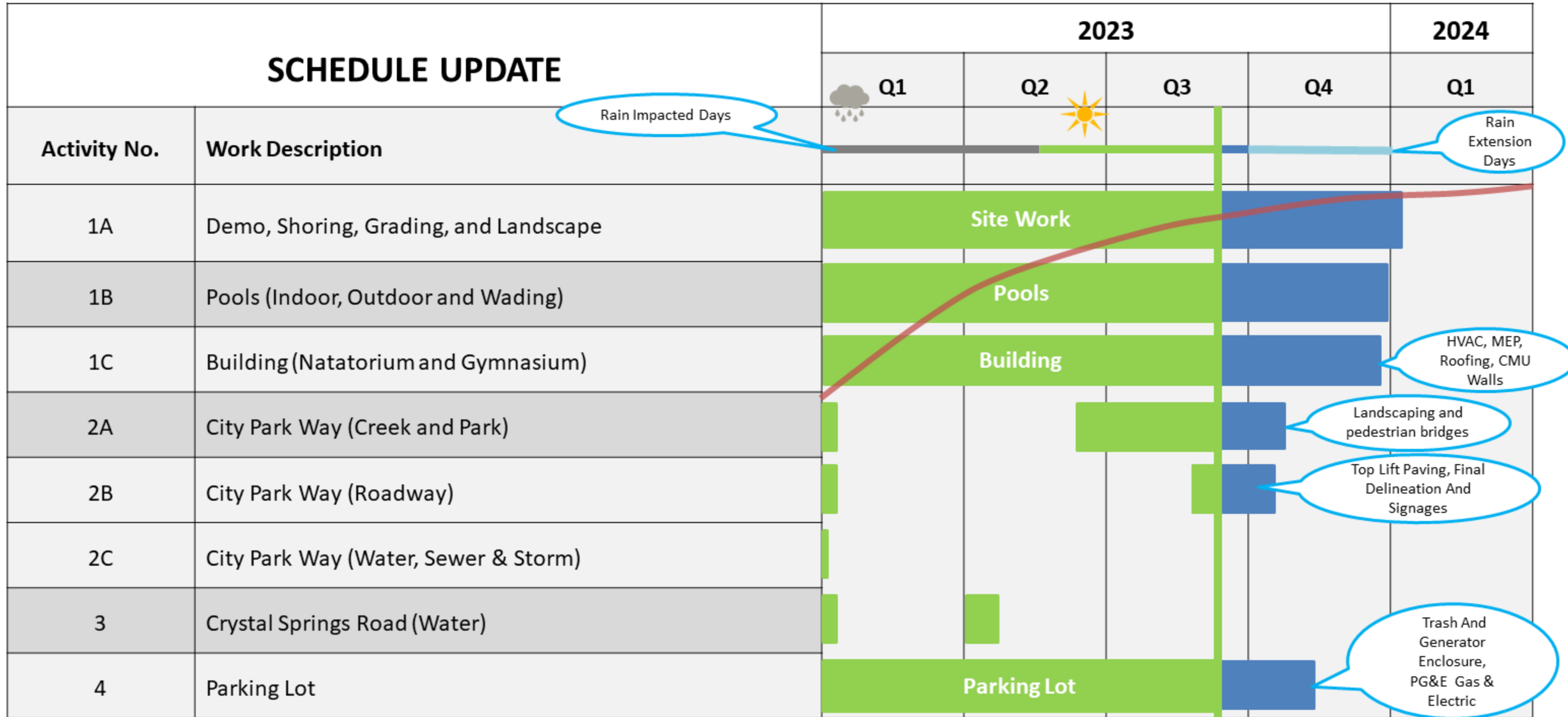

Construction Update and Look Ahead Schedule

PUBLIC OUTREACH



- Project Website is regularly updated
- Portable Changeable Message Boards will be used for Future Road Closures
- Detour Signs will be placed as needed
- Communicate with Google Navigation system as needed
- Field Contact Numbers are available on all project signs and City Website
- Daily onsite representative is available at the trailer office
- Calls and emails are being answered and addressed
- City Park Way daytime closure will continue for landscaping work
 - Nearby schools are being informed

Construction Update and Look Ahead Schedule

WHAT'S HAPPENING THE NEXT 30 DAYS AND BEYOND?



UPCOMING ONSITE WORK



ONSITE WORK

- Natatorium
 - Ceiling Taped, Topped, And Finished
 - Interior Painting
 - Suspended Ceiling Grid
 - MEPs
 - Roofing
 - Glass wall framing
- Indoor Pool
 - Pool Deck
 - Pool Deck Plumbing
 - Slot Drain Work
 - Pool Deck Electrical
 - Cantilevered Gutter
- Gymnasium
 - Elevator Cars
 - Insulation and Drywall
 - Windows
 - Main electrical room painting



Construction Update and Look Ahead Schedule

WHAT'S HAPPENING THE NEXT 30 DAYS AND BEYOND?



UPCOMING OFFSITE POOL AREA WORK



Chemical Room

Scaffolding and Outdoor Pools

OFFSITE WORK

- Chemical Room
- Outdoor Pool
 - Gutter
- Wading Pool
 - Rebar and shotcrete of Pool Bottom and Pool Walls
 - Gutter Rebar

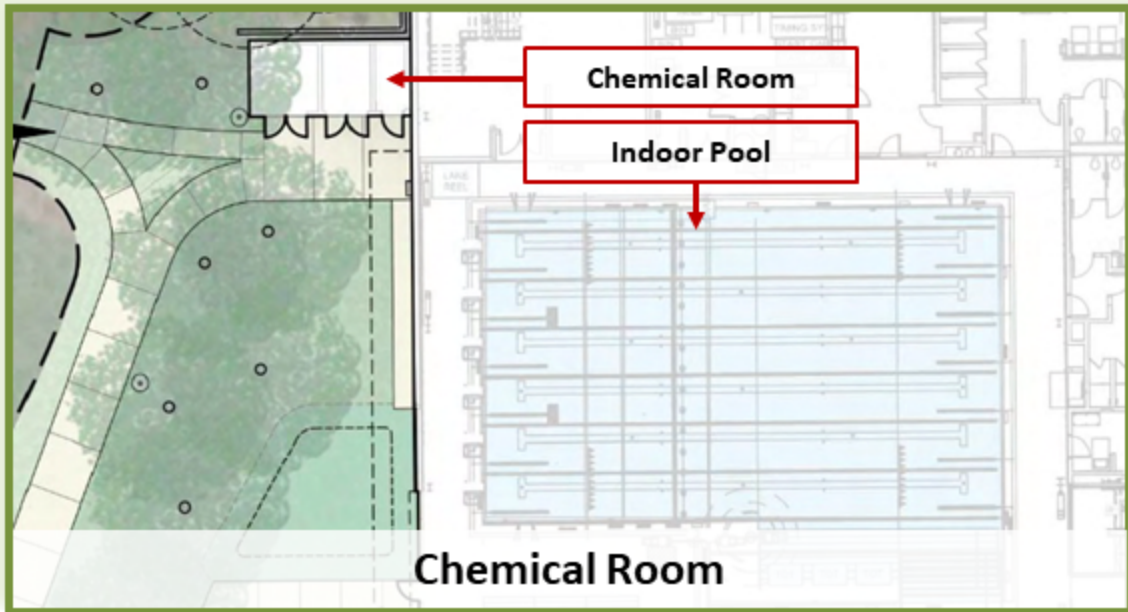

Chemical Room

Indoor Pool

Chemical Room



Outdoor Pool - Aerial

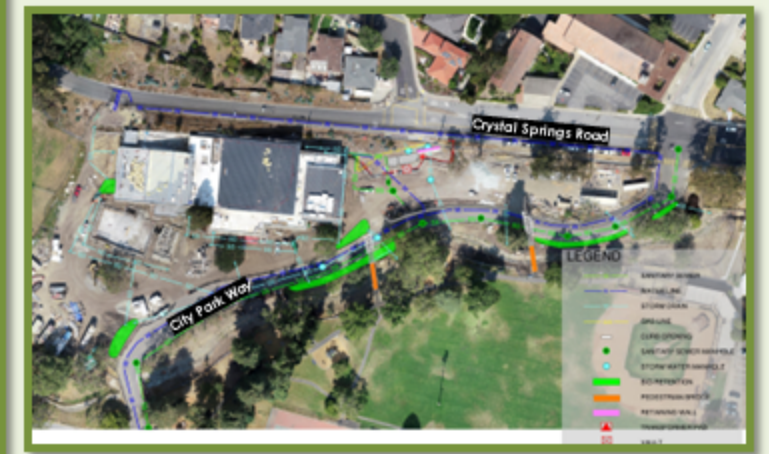

KEY MAP



Construction Update and Look Ahead Schedule

WHAT'S HAPPENING THE NEXT 30 DAYS AND BEYOND?

UPCOMING PARKING AREA WORK

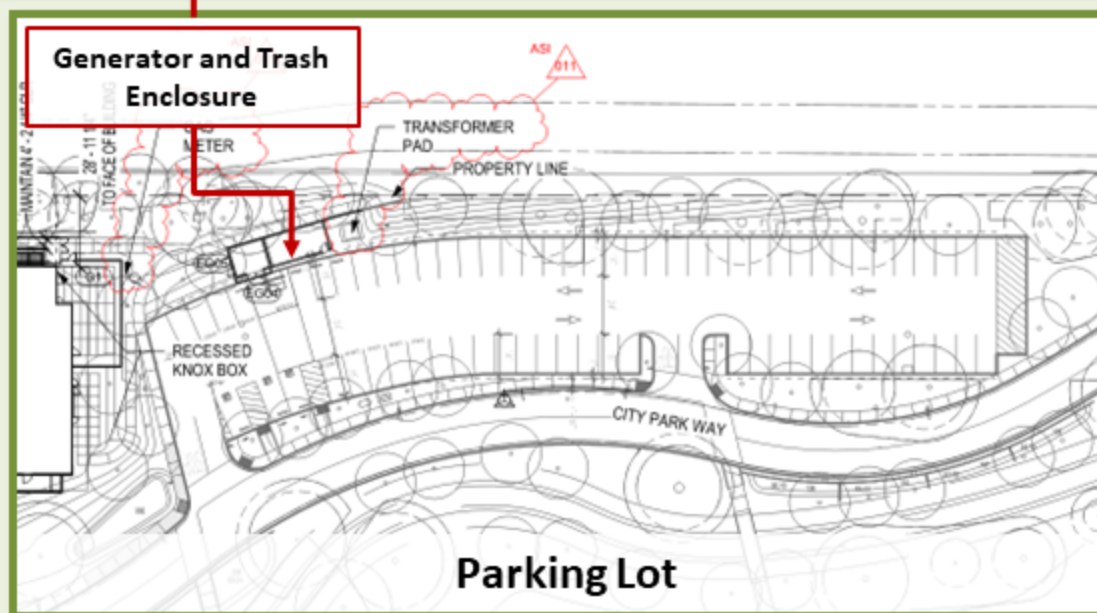
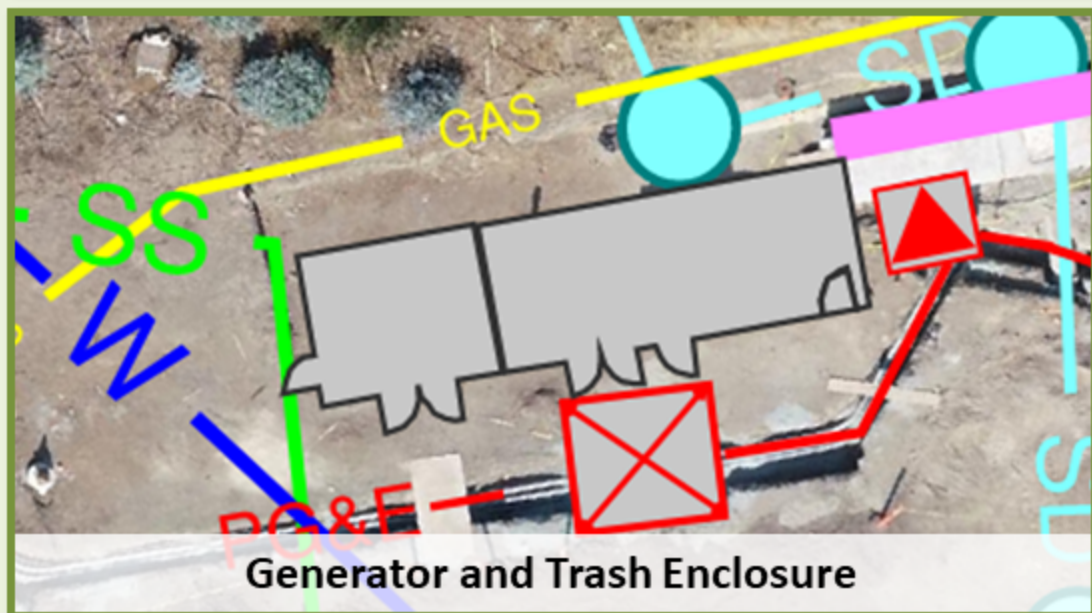
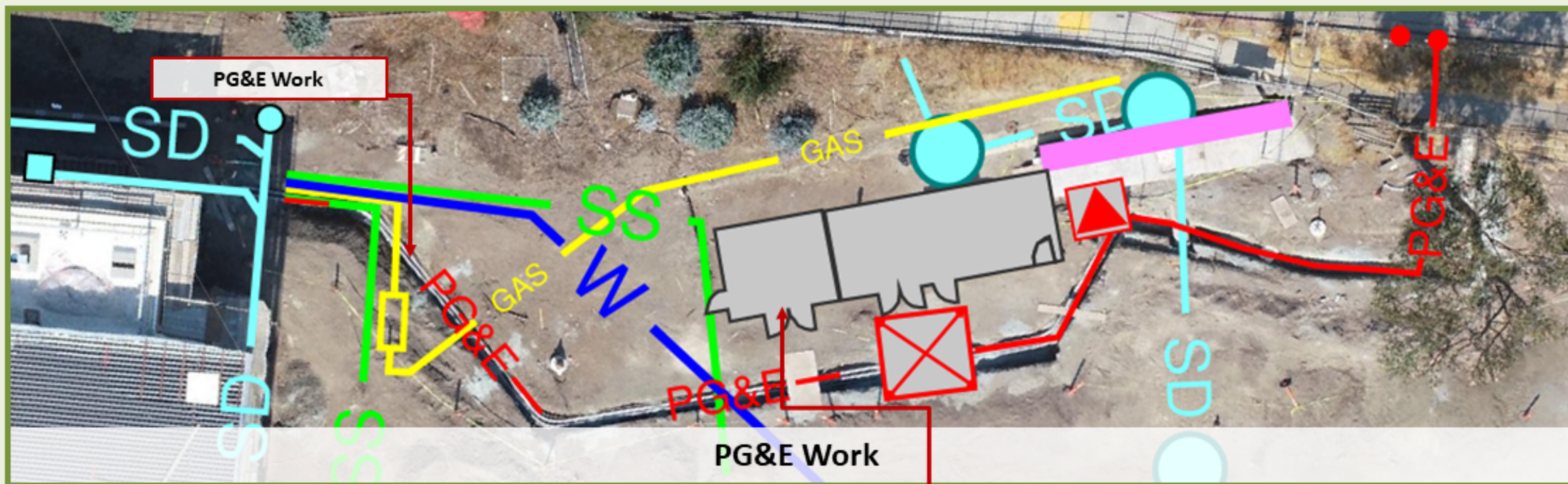

- OFFSITE WORK**
- Parking Lot
- PG&E Trench Backfill
 - Transformer Pad
 - Generator and Trash Enclosure Foundation



KEY MAP

Construction Update and Look Ahead Schedule

WHAT'S HAPPENING THE NEXT 30 DAYS AND BEYOND?



UPCOMING CITY PARK WAY AND ADOPTED PROJECTS WORK

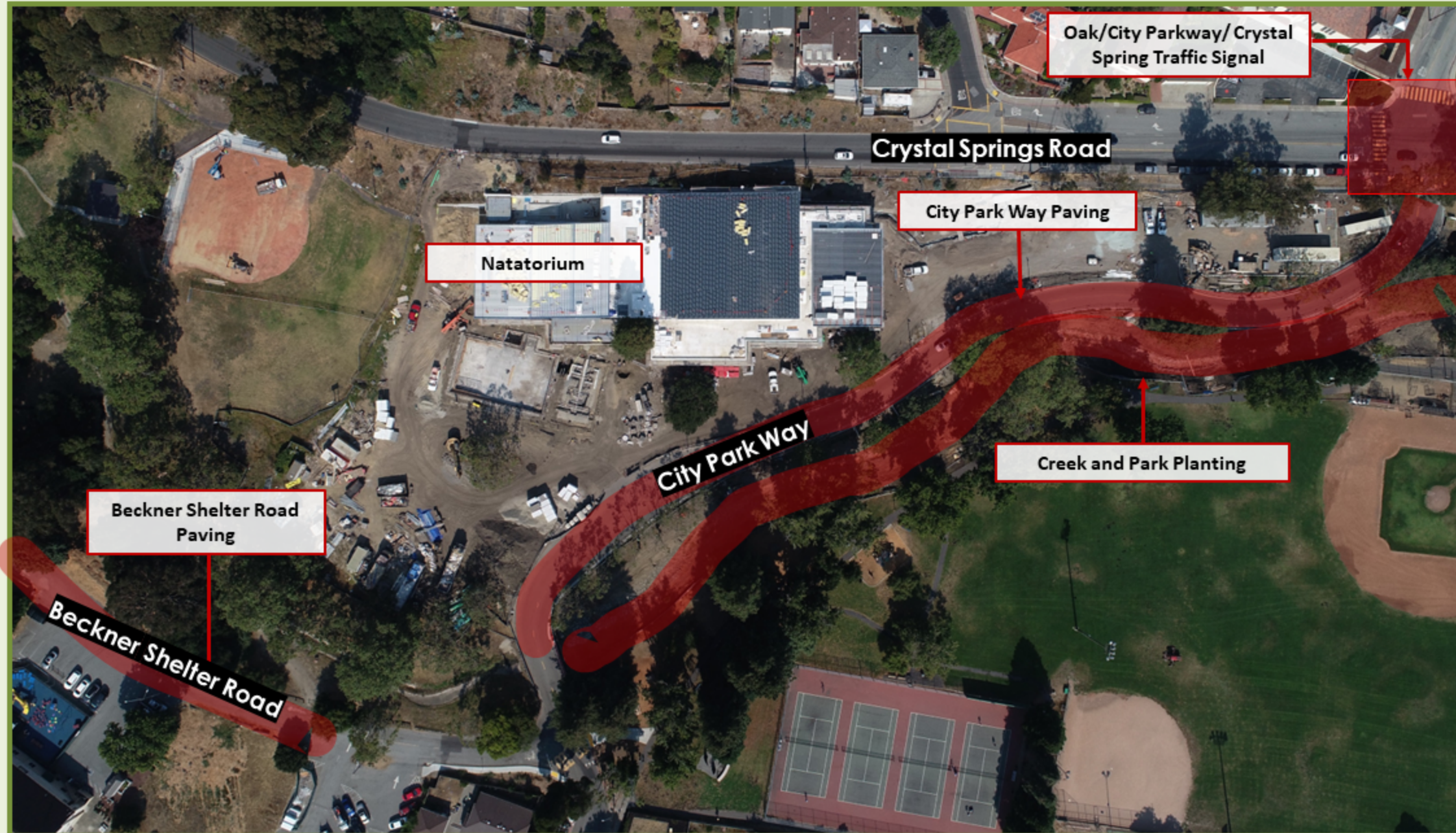

OFFSITE WORK

- City Park Way Paving
- Beckner Shelter Road Paving
- Traffic Signal Coordination

Creek

- Pedestrian Bridges
- Irrigation and Planting Along the Creek
- Bioswale



KEY MAP

Construction Update and Look Ahead Schedule

Crystal Springs / Oak Street / City Park Way Intersection Improvement

Project Update

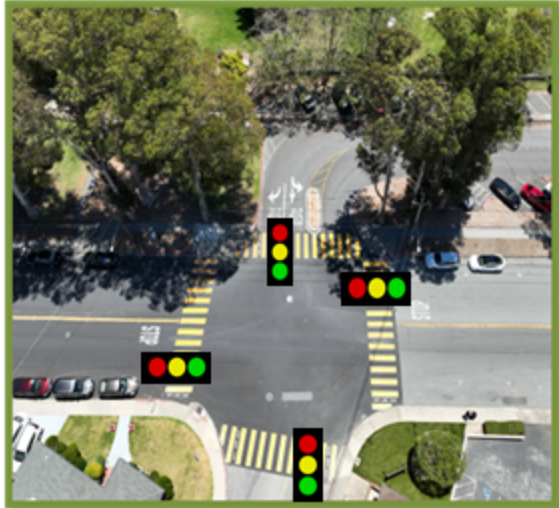

Traffic Signal System (TSS)

Traffic Engineer (T.E.) presented intersection traffic control alternatives to (TSPC) Traffic Safety and Parking Committee

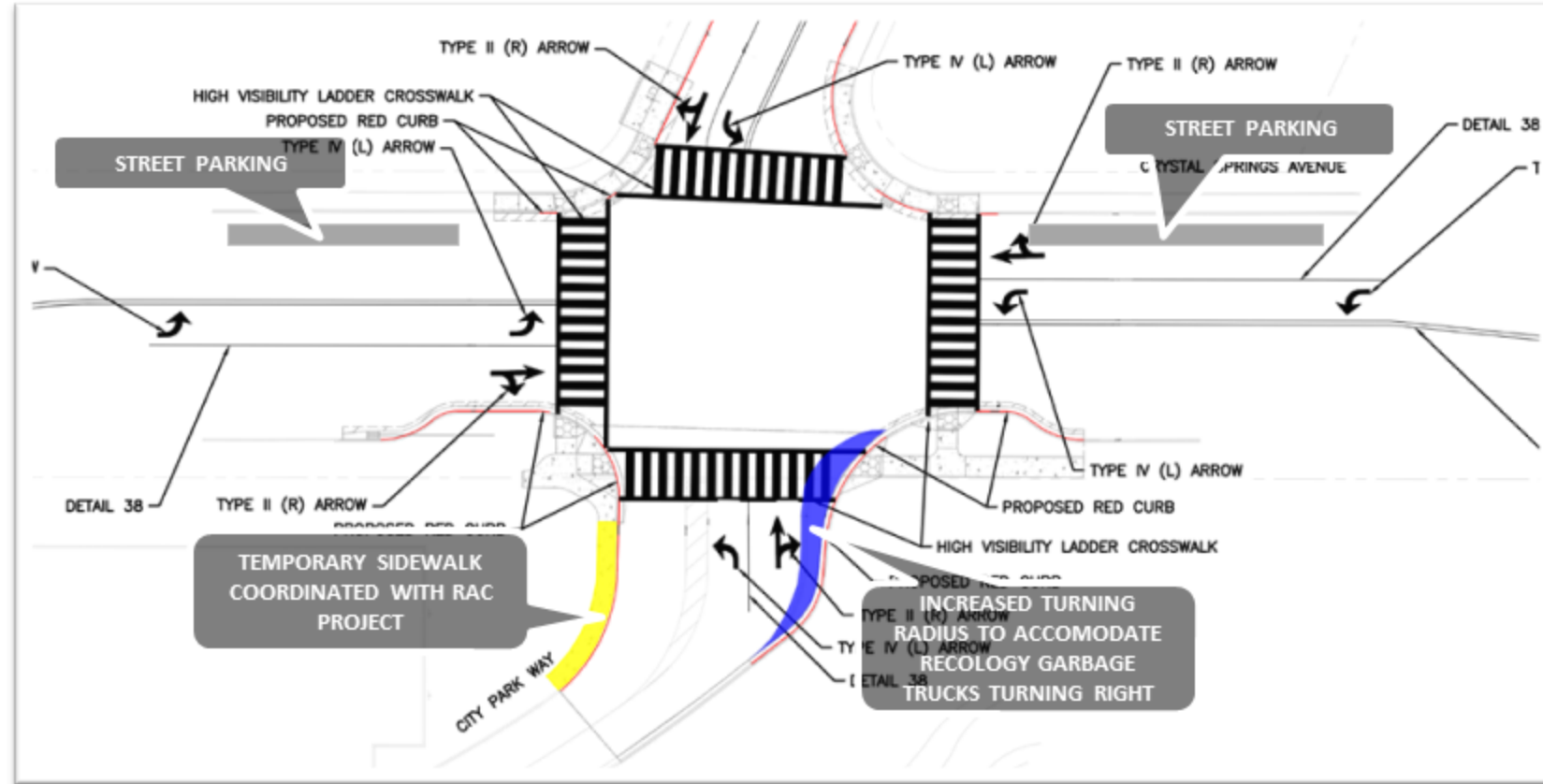

FUNDING SOURCES:
Measure A & G Fund (RAC)

PROJECT BUDGET:
\$800,000.00

SIGNAL POLE AND FOUNDATION DETAIL TO SHOW DEPTH AND SIZE

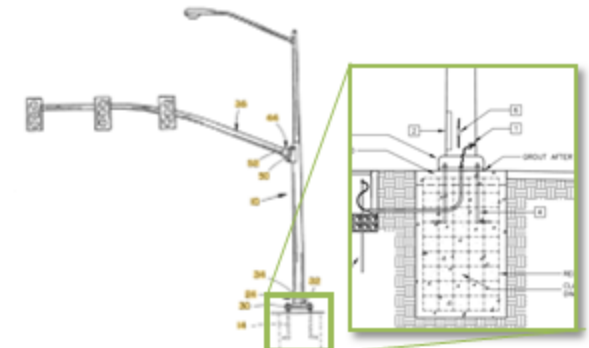

Designer proceeded with the TSS design preparation

Final Design Completed
Signal Poles Procurement Coordination

Advertise Project To Receive Bids

Completion Target



Per Vehicle Code, the City Engineer or T.E. to recommend the conclusion of the intersection control study. Memorandum to be issued.

Final Design to be completed (90%)

Received Bids and Rebidding Process

Construction NTP

Construction Update and Look Ahead Schedule

BECKNER SHELTER ROAD PROJECTS



PROJECTS	Design and Management Consultant Agreements	Topographic Surveying	Design Development	Complete Design	Request Quote or Process as Change Order	Begin Construction	Complete Construction
1 Repaving and Parking Lot Striping	●	●	●	September 2023 (Estimated)	October 2023 (Estimated)	October 2023 (Estimated)	November 2023 (Estimated)
2 ADA Bridge	●	●	September 2023 (Estimated)	October 2023 (Estimated)	November 2023 (Estimated)	December 2023 (Partially)	TBD (Permit Conditions)
3 Picnic Area #14 ADA Path	●	●	●	November 2023 (Estimated)	December 2023 (Estimated)	TBD	TBD

Ongoing

Completed



Change Order Report

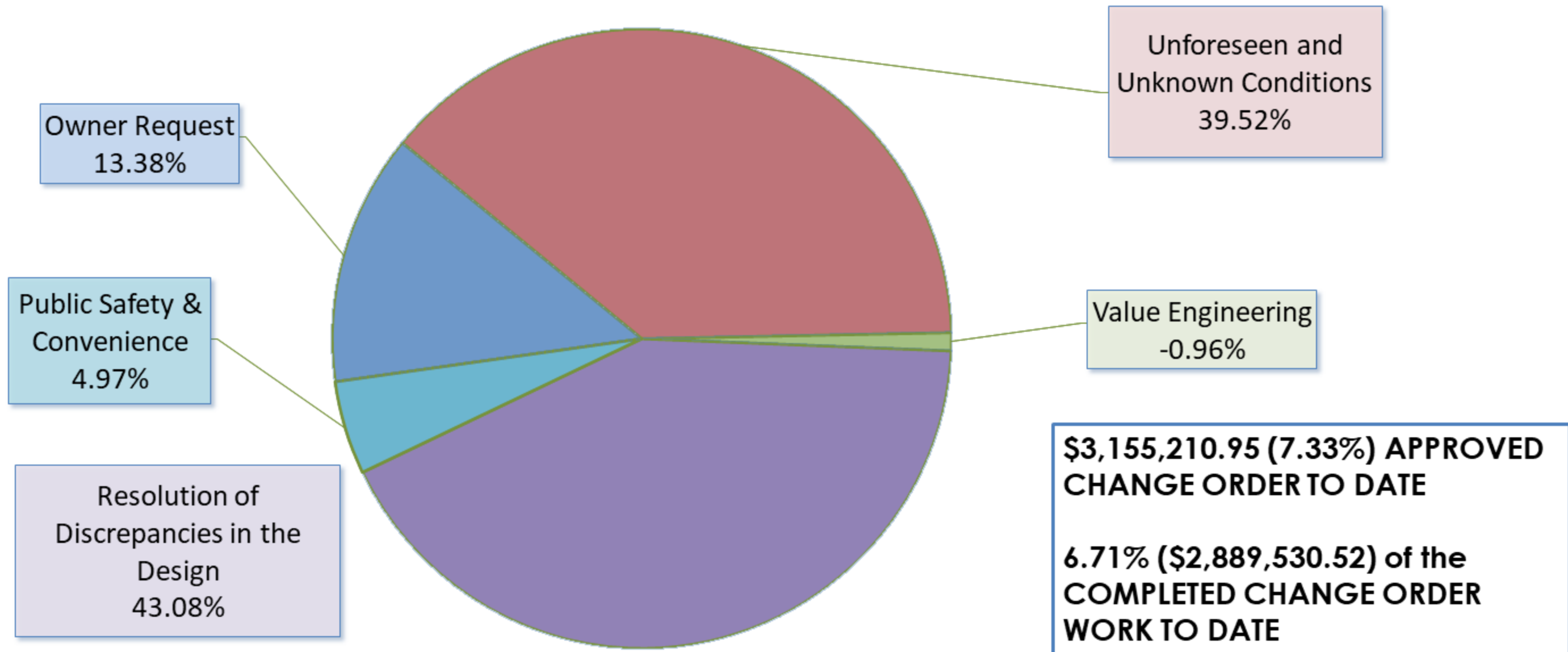

Construction Update and Look Ahead Schedule

Project Budget Update



Total Project Budget:

- \$62,290,228.00

Total Expenses To Date:

- \$45,852,480.09 (73.61%)

Pre-Construction Phase Cost Total:

- \$6,770,384.00

Construction Phase Cost To Date:

- \$39,082,096.09

SOFT COSTS

- Design (Group 4)
- Environmental
- Project Manager (Conсор)
- Construction Manager (Griffin Structures)
- Geotechnical, T&I, Waterproofing, Commissioning Services
- Lara Field Parking Lot
- Traffic Signals, Sewer, Water, Sidewalk, CityNet Fiber
- Temporary Space During Construction
- Furniture Fixtures and Equipment
- Electronic systems and special equipment
- Utility company connection and services
- Fees/ Administration/ Business Plan
- Additional Crystal Springs Tree Removal
- Beckner Shelter Projects

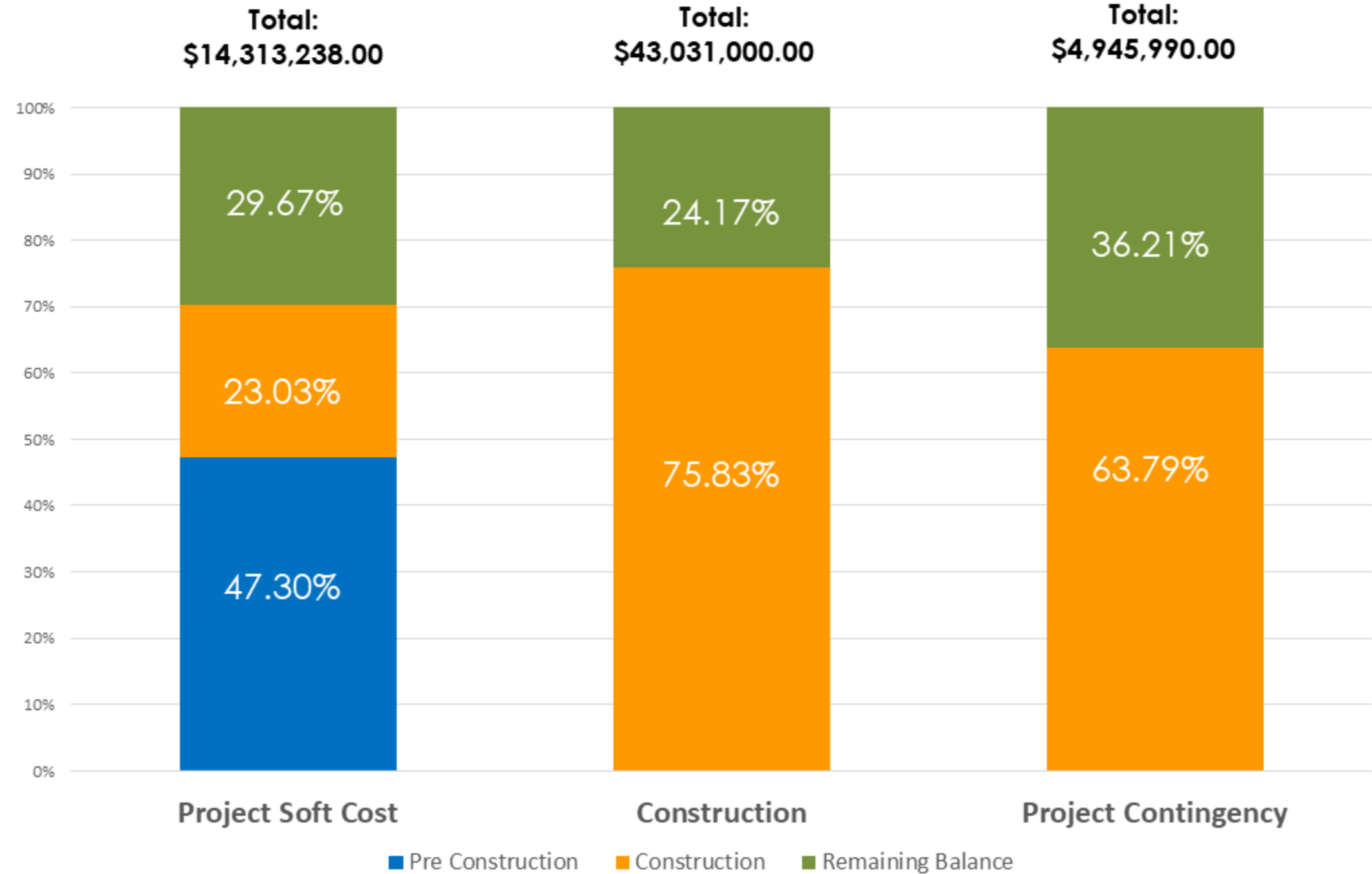

Construction Update and Look Ahead Schedule

OVERVIEW AND OUTLOOK

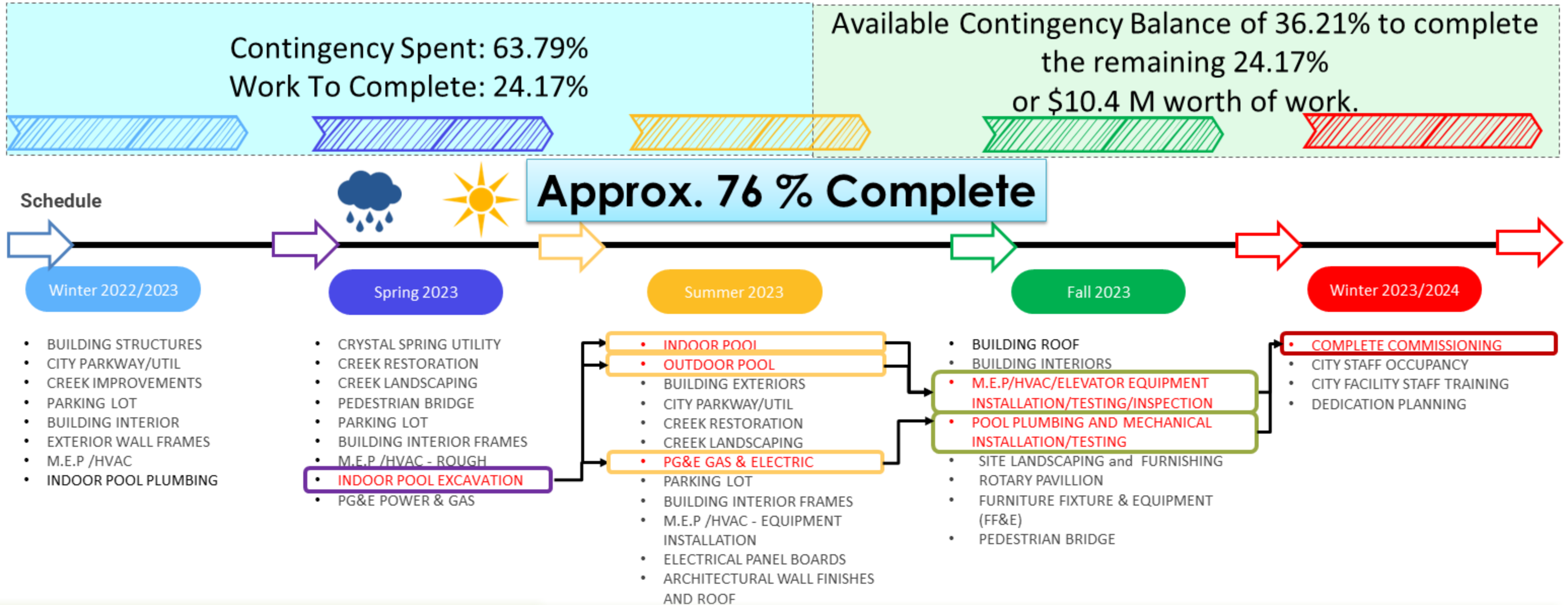

Contractor, Subcontractors and Manpower

- August Progress
 - Increased 26.44% from Feb-April compared to May – July 2023
- Overtime – General and Subcontractors
- More than 10 trades
- Average 35 to 60 people working

Project Management, Design Team and Construction Management

- 666 Request For Information (RFIs) Total, 657 RFIs answered
- 580 Submittals (Materials, work plan...etc.) Total Received, 558 reviewed
- 24 Change Orders Approved
- Conducted Commissioning Meeting
- Processing Consultant Agreements to maintain coverage.
- Project Budget Reconciliation – SBCF Grant Funds and Various City Funds
- Coordinating Adopted Projects:
 - Oak Avenue and Crystal Springs Intersection – Received Bids
 - Beckner Shelter Road Project design

Potential Risks To Schedule and Budget

- Weather
- PG&E Schedule
- Unforeseen Changes
- Material and Labor Availability
- Elevator – State Safety Inspector
- County Health Inspection (pool and kitchen)
- Adopted Projects Cost

THANK YOU

sanbruno.ca.gov/RecCenterBuild